

FLEXOBLOC® SEMI-ELASTIC COUPLINGS

TECHNICAL DATA SHEET
84005 - 1/2 - 08/97

SELECTION, ASSEMBLY AND DIMENSIONS



General characteristics

- Dampens vibrations and jerks
- Elastic element (disc) made of VULKOLAN®
Oil and hydrocarbon resistant
Use temperature range : -20°C to +70°C
- Flanges made of cast iron painted in black

Selection

- Calculate the service factor with the following table.

Load type	Driven machines	1,0	1,5	2,0
Light duty	Agitators - Conveyors - Centrifugal compressors - Dynamometers - Air filter - Generators - Shafts lines - Centrifugal pumps - Centrifugal fans	1,0	1,5	2,0
Medium duty	Agitators - Lifting material - Overshot elevator - Textile machinery - Machine tools - Wood working machinery - Mixers - Gyrotory pumps - Printing presses - Hoist - Mining fans	1,5	2,0	2,5
High duty	Lifting material - Hammer mills - Crushers - Rotative compressors - Dredgers - Calenders - Gyrotory furnaces - Brick machinery - Cutting presses	2,0	2,5	3,0
High inertia Shocks Torque inversion Rotation inversion	Gyrotory crushers - Alternative conveyors - Vibrating screens - Alternative compressors Rubber calenders - Mills - Alternative pumps	2,5	3,0	3,5

- Calculation of the power at 100 rpm.
- Determination of the size of the coupling based on the power at 100 rpm and on the service factor (see following table)

Size	maxi Speed rpm	transferable power at 100 rpm according to the service factor					Nominal torque Nm
		Service factor					
		1	1,5	2	2,5	3	
90	3000	0,44	0,29	0,22	0,18	0,15	40
100	3000	1,03	0,69	0,52	0,41	0,34	90
132	3000	1,84	1,23	0,92	0,74	0,61	180
180	3000	3,68	2,45	1,84	1,47	1,23	360
200	1500	7,36	4,91	3,68	2,94	2,45	710

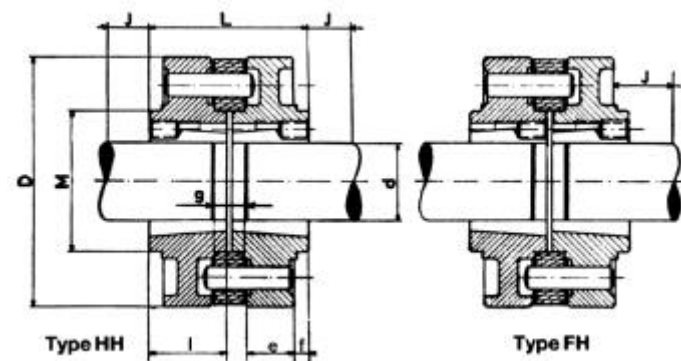

Installation

- Install the bushes in the flanges.
- Set one of the flanges on the shaft and clamp it, the bush must flush with the end of the shaft.
- Slide the second flange with its disc on the second shaft.
- Set and align the shafts. The G dimension must be correct between the shafts for the rapid disassembly of the apparatus.
- Check the alignment with a rule for the axial alignment and with a calliper square for the angular alignment. 4 points at 90° must be controlled.
- Couple the two flanges by making the free one slide against the one clamped.
- Tighten the screws of the bush.
- Several positions of assembling the bush (see next schema)

Dimensional and technical characteristics

Size	Bush		assembled flanges									Fingers		J	Weight with no bush (kg)
	International	VECOBLOC®	d	D	L	l	M	e	f	g	Nber	Ø			
90	1108	28.20	28	90	50	20	-	20	-	10	3	10	30	1,3	
100	1215	30.40	30	105	83	40	60	28	6	13	4	10	30	2,5	
132	1615	40.40	40	130	83	40	75	25	7,5	16	4	12	30	3,6	
180	2517	65.45	65	180	94	45	110	31	7	17	5	16	45	8,0	
200	3020	75.50	75	215	113	50	130	38	6	22	6	20	55	13,5	

COLMANT CUEVELIER S.A.

rue Greuze - B.P. 529 - 59022 LILLE CEDEX - FRANCE

tél : (33) 03 20 67 79 01 - fax : (33) 03 20 67 79 79



"A.R." RIGID COUPLINGS

SELECTION, ASSEMBLY AND DIMENSIONS

FICHE TECHNIQUE
84005 - 2/2 - 08/97
TECHNICAL DATA SHEET



General characteristics

- Transmits high torques in difficult conditions.
- A cover for the coupling is not necessary (no protruding element).
- Material : Cast iron - steel on demand.

Selection

- Calculate the torque to transfer (Nm)

P : power (kW)

N : rotation speed (rpm)

$$C = 9550 \times \frac{P}{N}$$

- Choose the coupling with an admissible torque superior or equal to the torque to transfer, according to the load type (see following table)

Size	Admissible torque (Nm)	
	Load type 1	Load type 2
AR 40	500	250
AR 50	950	500
AR 65	2100	1000
AR 75	3250	2000
AR 90	5600	4000

Load type 1 : where maximum torque in more than twice nominal torque

Load type 2 : hard conditions, high inertia, maxi. torque in case of reversing of work

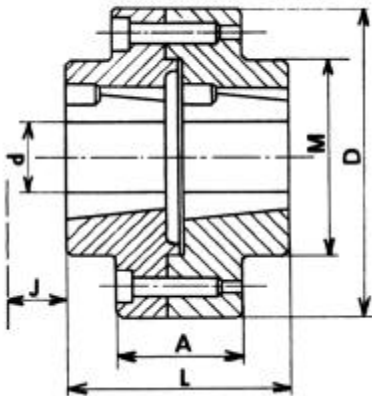

Installation

- Set the bushes in the flanges.
- Set the female flange on the shorter shaft, the bush flushing with the end of the shaft. Tighten the screws of the bush.
- Slide the flange on the shaft.
- Set and align the shafts to couple. The alignment can be checked with a rule for the axial alignment and with a calliper square for the angular alignment. 4 points at 90 ° must be checked.
- Slide the male flange against the female one. Tighten the A screws.
- Tighten the screws of the bush on the male flange. One shaft can be axialment free during the tightening.

Dimensional and technical characteristics

Size	Bush		Assembled flanges								Key	J	Weight without bush (kg)
	International	VECOBLOC®	d maxi	D	L	M	A	Chc screws					
								Nber	Ø	length.			
AR 40	1615	40.40	42	125	87	80	43	4	10	30	8	30	3,7
AR 50	2012	50.30	50	155	68	110	40	6	10	30	8	40	5,2
AR 65	2517	65.45	65	180	98	120	48	6	12	35	10	45	8,65
AR 75	3020	75.50	75	215	108	150	60	6	14	45	12	55	15,3
AR 90	3535	90.90	90	250	188	180	60	8	14	50	12	70	33,1

COLMANT CUVELIER S.A.

rue Greuze - B.P. 529 - 59022 LILLE CEDEX - FRANCE

tél : (33) 03 20 67 79 01 - fax : (33) 03 20 67 79 79

