

DIMENSIONAL FEATURES

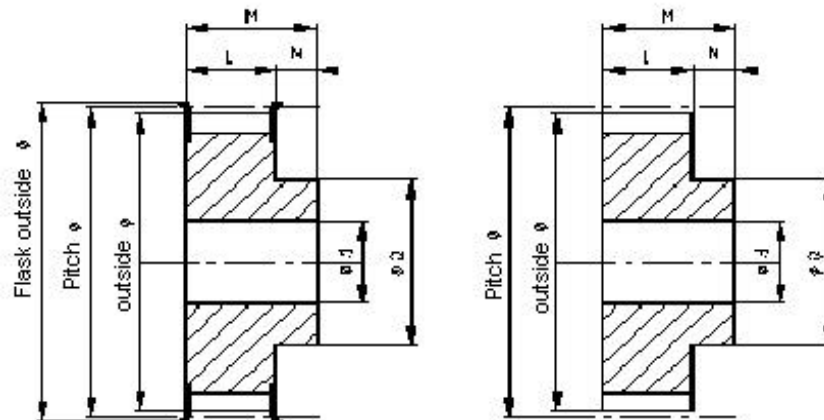

Type 1

Type 2

Designation

31	T10	20	F
Total width (M)	Pitch	Nb. of teeth	flasked

Pitch T10 (10 mm) for Timing Belt - Width 16 mm

	Pitch ø (outside ø)									
31T1012F	38.20 (36.35)	1	6	16	21	42	31	10	28	0.076
31T1014F	44.56 (42.70)	1	8	19	21	48	31	10	32	0.104
31T1015F	47.75 (45.90)	1	8	19	21	51	31	10	32	0.116
31T1016F	50.93 (49.05)	1	8	22	21	54	31	10	35	0.134
31T1018F	57.30 (55.45)	1	8	24	21	60	31	10	40	0.167
31T1019F	60.48 (58.60)	1	8	28	21	66	31	10	44	0.184
31T1020F	63.66 (61.80)	1	8	28	21	66	31	10	46	0.208
31T1022F	70.03 (68.15)	1	8	32	21	75	31	10	52	0.249
31T1024F	76.39 (74.55)	1	8	38	21	83	31	10	58	0.288
31T1025F	79.58 (77.70)	1	8	38	21	83	31	10	60	0.310
31T1026F	82.76 (80.90)	1	8	38	21	87	31	10	60	0.337
31T1027F	85.94 (84.10)	1	8	38	21	91	31	10	60	0.364
31T1028F	89.13 (87.25)	1	8	38	21	93	31	10	60	0.399
31T1030F	98.49 (93.65)	1	8	38	21	97	31	10	60	0.441
31T1032F	101.86 (100.00)	1	10	42	21	106	31	10	65	0.493
31T1036F	114.59 (112.75)	1	10	50	21	119	31	10	70	0.623
31T1040F	127.32 (125.45)	1	10	55	21	131	31	10	80	0.767
31T1044F	140.06 (138.20)	2	10	60	21		31	10	88	0.932
31T1048F	152.79 (150.95)	2	16	60	21		31	10	95	1.090
31T1060F	190.99 (189.10)	2	16	70	21		31	10	110	1.701

* with keying : Norm NFE 22175
Cast iron FGL 250, Protection by phosphatation or black paint.

COLMANT CUVELIER S.A.

rue Greuze - B.P. 529 - 59022 LILLE CEDEX - FRANCE

tél : (33) 03 20 67 79 01 - fax : (33) 03 20 67 79 79



DIMENSIONAL FEATURES

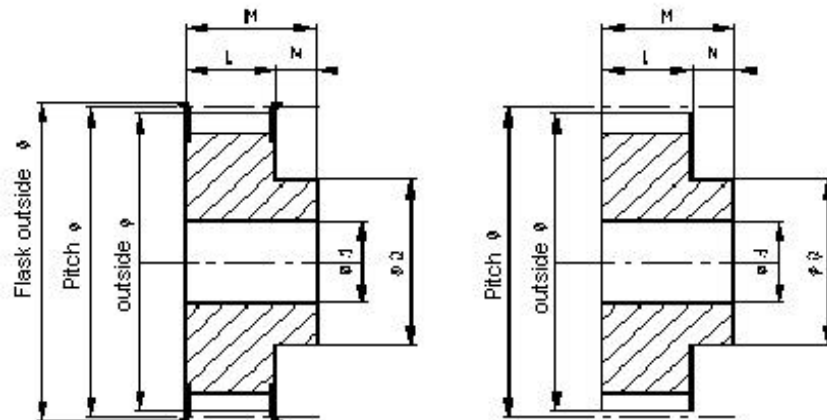

Type 1

Type 2

Designation

40	T10	20	F
Total width (M)	Pitch	Nb. of teeth	flasked

Pitch T10 (10 mm) for Timing Belt – Width 25 mm

	Pitch ϕ (outside ϕ)									
40T1012F	38.20 (36.35)	1	6	16	30	42	40	10	28	0.099
40T1014F	44.56 (42.70)	1	8	19	30	48	40	10	32	0.134
40T1015F	47.75 (45.90)	1	8	19	30	51	40	10	32	0.152
40T1016F	50.93 (49.05)	1	8	22	30	54	40	10	35	0.176
40T1018F	57.30 (55.45)	1	8	24	30	60	40	10	40	0.224
40T1019F	60.48 (58.60)	1	8	28	30	66	40	10	44	0.247
40T1020F	63.66 (61.80)	1	8	28	30	66	40	10	46	0.276
40T1022F	70.03 (68.15)	1	8	32	30	75	40	10	52	0.378
40T1024F	76.39 (74.55)	1	8	38	30	83	40	10	58	0.392
40T1025F	79.58 (77.70)	1	8	38	30	83	40	10	60	0.422
40T1026F	82.76 (80.90)	1	8	38	30	87	40	10	60	0.485
40T1027F	85.94 (84.10)	1	8	38	30	91	40	10	60	0.536
40T1028F	89.13 (87.25)	1	8	38	30	93	40	10	60	0.585
40T1030F	98.49 (93.65)	1	8	38	30	97	40	10	60	0.640
40T1032F	101.86 (100.00)	1	10	42	30	106	40	10	65	0.693
40T1036F	114.59 (112.75)	1	10	50	30	119	40	10	70	0.873
40T1040F	127.32 (125.45)	1	10	55	30	131	40	10	80	1.067
40T1044F	140.06 (138.20)	2	10	60	30		40	10	88	1.310
40T1048F	152.79 (150.95)	2	16	60	30		40	10	95	1.516
40T1060F	190.99 (189.10)	2	16	70	30		40	10	110	2.339

* with keying : Norm NFE 22175

Cast iron FGL 250, Protection by phosphatation or black paint.

COLMANT CUVELIER S.A.

rue Greuze - B.P. 529 - 59022 LILLE CEDEX - FRANCE

tél : (33) 03 20 67 79 01 - fax : (33) 03 20 67 79 79



DIMENSIONAL FEATURES

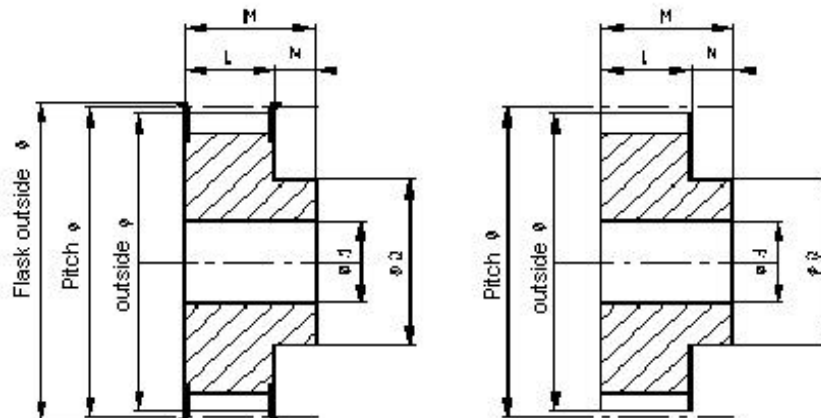

Designation

Type 1

Type 2

47	T10	20	F
Total width (M)	Pitch	Nb. of teeth	flasked

Pitch T10 (10 mm) for Timing Belt - Width 30 mm

	Pitch ø (outside ø)									
47T1018F	57.30 (55.45)	1	10	24	37	60	47	10	40	0.422
47T1019F	60.48 (58.60)	1	10	28	37	66	47	10	44	0.466
47T1020F	63.66 (61.80)	1	12	28	37	66	47	10	46	0.520
47T1022F	70.03 (68.15)	1	12	32	37	75	47	10	52	0.631
47T1024F	76.39 (74.55)	1	12	38	37	83	47	10	58	0.736
47T1025F	79.58 (77.70)	1	12	38	37	83	47	10	60	0.766
47T1026F	82.76 (80.90)	1	12	38	37	87	47	10	60	0.847
47T1027F	85.94 (84.10)	1	12	38	37	91	47	10	60	0.946
47T1028F	89.13 (87.25)	1	12	38	37	93	47	10	60	1.074
47T1030F	98.49 (93.65)	1	12	38	37	97	47	10	60	1.169
47T1032F	101.86 (100.00)	1	12	42	37	106	47	10	65	1.300
47T1036F	114.59 (112.75)	1	16	50	37	119	47	10	70	1.637
47T1040F	127.32 (125.45)	1	16	55	37	131	47	10	80	1.999
47T1044F	140.06 (138.20)	2	16	60	37		47	10	88	2.386
47T1048F	152.79 (150.95)	2	16	60	37		47	10	95	2.830
47T1060F	190.99 (189.10)	2	16	70	37		47	10	110	4.366

* with keying : Norm NFE 22175

Cast iron FGL 250, Protection by phosphatation or black paint.

COLMANT CUVELIER S.A.

rue Greuze - B.P. 529 - 59022 LILLE CEDEX - FRANCE

tél : (33) 03 20 67 79 01 - fax : (33) 03 20 67 79 79



DIMENSIONAL FEATURES

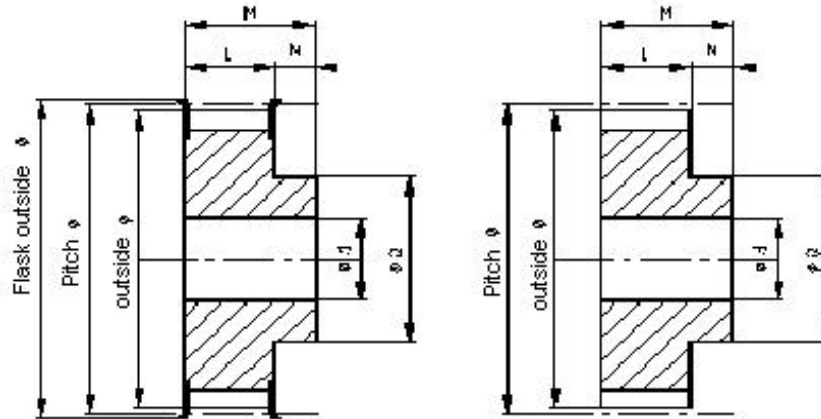

Type 1

Type 2

Designation

66	T10	20	F
Total width (M)	Pitch	Nb. of teeth	flasked

Pitch T10 (10 mm) for Timing belt - Width 50 mm

	Pitch ø (outside ø)									
66T1018F	57.30 (55.45)	1	10	24	56	60	66	10	40	
66T1019F	60.48 (58.60)	1	10	28	56	66	66	10	44	
66T1020F	63.66 (61.80)	1	12	28	56	66	66	10	46	
66T1022F	70.03 (68.15)	1	12	32	56	75	66	10	52	
66T1024F	76.39 (74.55)	1	12	38	56	83	66	10	58	
66T1025F	79.58 (77.70)	1	12	38	56	83	66	10	60	
66T1026F	82.76 (80.90)	1	12	38	56	87	66	10	60	
66T1027F	85.94 (84.10)	1	12	38	56	91	66	10	60	
66T1028F	89.13 (87.25)	1	12	38	56	93	66	10	60	
66T1030F	98.49 (93.65)	1	12	38	56	97	66	10	60	
66T1032F	101.86 (100.00)	1	12	42	56	106	66	10	65	
66T1036F	114.59 (112.75)	1	16	50	56	119	66	10	70	
66T1040F	127.32 (125.45)	1	16	55	56	131	66	10	80	
66T1044F	140.06 (138.20)	2	16	60	56		66	10	88	
66T1048F	152.79 (150.95)	2	16	60	56		66	10	95	
66T1060F	190.99 (189.10)	2	16	70	56		66	10	110	

* with keying : Norm NFE 22175

Cast iron FGL 250, Protection by phosphatation or black paint.